



Three-phase electrode boilers

Models:

BE/BEH

3-3 (3kW)

3-6 (6kW)

3-9 (9kW)

3-12 (12kW)

3-15 (15kW)

3-18 (18kW)

3-25 (25kW)

3-50 (50kW)



1. Purpose

"GAZDA" electrode boilers (water heaters) are designed for:

- installation of individual closed-type heating systems
- construction of interconnected closed heating systems by connecting an electrode boiler in parallel to an existing boiler (gas, solid fuel or other type)
- installation of an underfloor heating system
- installation of hot water heating systems via a heat exchanger

2. Equipment design and principle of operation

The GAZDA water heater consists of a metal casing with inlet and outlet pipes and a pin electrode mounted in a sealed housing through an insulator.

The boiler casing and inlet and outlet pipes are insulated to ensure safe and reliable operation when supplied with RCD or residual current circuit breaker.

The principle of the electrode water heater is to direct conversion of electricity into heat energy when alternating current flows through the coolant from one electrode to another. Therefore, the power of the heater depends directly on the electrical conductivity (resistivity) of the heat transfer medium (water).

The function of the second electrode is performed by the metal housing of the water heater, so for safety reasons the neutral wire is connected to the housing and the phase wire to the pin electrode.

A characteristic feature of electrode water heaters is the gradual increase in current consumption and, correspondingly, the increase in power supplied to the system in proportion to the increase in the temperature of the heat carrier (water).

The electrodes of the KE water heaters are made of ferrous metal alloy and the electrodes of the KEH water heaters are made of non-ferrous metal alloy.

3. Main technical parameters

Table 1

	Characteristics	Boiler model							
		BE/BEH 3-3	BE/BEH 3-6	BE/BEH 3-9	BE/BEH 3-12	BE/BEH 3-15	KE/KEH 3-18	KE/KEH 3-25	KE/KEH 3-50
1	Heated area, m ²	20...30	60...80	90...110	120...150	150...180	180...220	250...310	500...630
2	Cubic capacity of heated room, m ³	80...110	170...220	250...310	330...420	420...500	500...600	700...850	1400.1700
3	Power, kW:								
	maximum	2,0	4,5	7,0	10,0	12,0	15,0	22,0	40,0
	evaluation	3,0	6,0	9,0	12,0	15,0	18,0	25,0	50,0
4	Supply voltage 50/60 Hz. W	3x400	3x400	3x400	3x400	3x400	3x400	3x400	3x400
5	Water heater current, A:								
	Rated	3,1	6,8	10,6	15,2	18,2	22,5	33,0	61,0
	maximum	4,6	9,1	13,7	18,2	22,7	27,0	37,5	77,0
6	Electrical conductivity of the heat transfer medium, uS/sm at 20°C:								
	for rated power for	350	350	350	350	350	350	350	350
	maximum power	450	450	450	450	450	450	450	450
7	Cross-section of the supply cable, (copper) mm ²	1,5	1,5	2,5	4,0	4,0	4,0	6,0	2x6,0
8	Maximum volume coolant, litres	30	60	100	140	180	180	250	600
9	Size of connections to the system	Ø20.0mm (3/4")	Ø20.0mm (3/4")	Ø20.0mm (3/4")	Ø20.0mm (3/4")	Ø20.0mm (3/4")	Ø32.0mm (1 1/4")	Ø32.0mm (1 1/4")	Ø32.0mm (1 1/4")
10	Protection class against electric shock. current	1	1	1	1	1	1	1	1
11	Degree of protection against humidity	IP34	IP34	IP34	IP34	IP34	IP34	IP34	IP34
12	Overall (installation) dimensions, mm	85x150 x220	85x150 x220	85x150 x330	85x150 x330	85x150 x330	165x100 x390	165x100 x430	220x140 x480
13	Weight (kg)	2,10	2,20	2,65	2,80	2,95	5,20	5,80	9,70

4. Indication of security measures

The water heater is under dangerous voltage!

The installation of the water heater supply and control circuit must be carried out by electricians who are familiar with these operating instructions and are suitably qualified and authorised.

When operating and maintaining the water heater, the requirements of the "Principles of technical operation of electrical installations for end users" must be observed.

The water heater must be operated in a room with a relative humidity of up to 80%.

The air should be free of acids, alkalis and other aggressive elements.

Exposed electrically conductive parts of the heating system must be earthed. The design of the earthing device must comply with the PUE requirements. The earthing resistance of the boiler shall be no more than 40M.

The supply lines to the water heater must have a cross-section not less than that specified in point 7 of Table 1.

The electrical switching and control equipment of the water heater must be designed for a current not less than that specified in point 5 of Table 1.

The heating system in which the water heater is installed must not contain any shut-off or control valves in the area from the boiler outlet to the safety group or expansion tank.

5. Installation of the heating system

Before installing the water heater, remove the protective covers and check the inside of the water heater for visible damage and foreign bodies after transport and storage.

The water heater must be installed vertically on the wall (brick, concrete, foam concrete, etc.).

Fix the water heater to the wall using the clamps provided (item 10).

In a system without a circulation pump, the water heater must be fixed so that its inlet pipe is below the axis of the bottom pipe of the nearest radiator.

For all systems, a distance at least equal to the height of the water heater should be left from the lowest point of the water heater to the floor to allow the electrode to be removed for maintenance.

If the water heater is installed in a system without a circulation pump, the riser height above the water heater must be in accordance with the design.

If the water heater is installed in a system with a circulation pump, the riser height above the water heater must be at least at least 0.4 m (to allow the water heater to operate on the nearest radiator in the event of a pump failure).

A closed type heating system must necessarily include a group of safety valve (pressure valve, pressure gauge and air vent) - as close as possible to the hot water outlet of the electrode boiler.

6. Preparation of brine (water)

The main and decisive parameter of the heating medium for an electrode water heater is its electrical conductivity. Electrical conductivity is a numerical expression of the ability of a solution to conduct electricity. The unit of measure for electrical conductivity is S/sm (S - Siemens). The higher the numerical value of the electrical conductivity of the coolant, the higher the current and, accordingly, the power of the water heater. The instrument for measuring the electrical conductivity of solutions is the conductivity meter.

The numerical expression of the electrical conductivity is inversely proportional to the numerical expression of the resistivity of the coolant, which is measured in ohms/div. This means that the lower the numerical value of resistivity, the higher the current (and power) of the water heater.

The most efficient operation of electrode water heaters is achieved when the electrical conductivity of the coolant is 300...500 $\mu\text{s}/\text{sm}$ (resistivity 1600...1300 Ohm/cm) at 20°C (this value also varies with coolant temperature). The more precise value for a particular brand of water heater depends on its design, namely the working area of the electrodes.

For GAZDA water heaters, the electrical conductivity of the coolant should be 350/450 $\mu\text{s}/\text{sm}$ (see item 6 of Table 1).

Therefore, a specialised low-boiling fluid can be used as the coolant for the electrode water heater (for the construction of the non-freezing heating systems) or a water-based solution with a certain level of electrical conductivity.

For self-preparation of coolant, it is recommended to use water purified from all impurities (distilled, rain, snow) in which baking soda has been dissolved at a rate of 30 grams per 100 litres of water. In this case, the amount of 'base' coolant prepared should exceed the capacity of the system by 20...30%. The excess coolant should be drained into a convenient container and stored - it will be needed in the event of a leak or to top up the system with an open expansion tank.

The coolant should be prepared in a clean glass or plastic container. Within 15...20 minutes after the soda is completely dissolved, the electrical conductivity of the resulting coolant should be measured using a conductivity meter. If the value is not equal to 350 (450) $\mu\text{s}/\text{sm}$, adjust it to the desired value by adding baking soda (conductivity increases) or distilled water (conductivity decreases).

If you do not have a conductivity meter, pour the pre-prepared solution (30 grams of baking soda per 100 litres of water) into the system and make adjustments during the initial start-up of the water heater. This involves measuring the minimum current at the start of the water heater start-up and/or the maximum current when the maximum (set) water temperature is reached at the water heater outlet using an ammeter or current clamps and adjusting the current to the passport values (as defined in section 8 "Start-up, operation and maintenance of the system"). The current intensity can be adjusted by adding baking soda (increase in current) or distilled water (decrease in current) to the coolant by replacing parts of the coolant with parts of the correction fluid.

7. Options and installation of water heater control automation

IS-TOK supplies three types of automation for the control of heating systems with GAZDA water heaters: 'Classic' (touchscreen), and 'Lux-KROS' (solid-state).

7.1 Automatic "Classic" - controls the boiler via a TP-16 thermostat, automatically maintaining the temperature of the heating medium set by the user.

Fig. 1

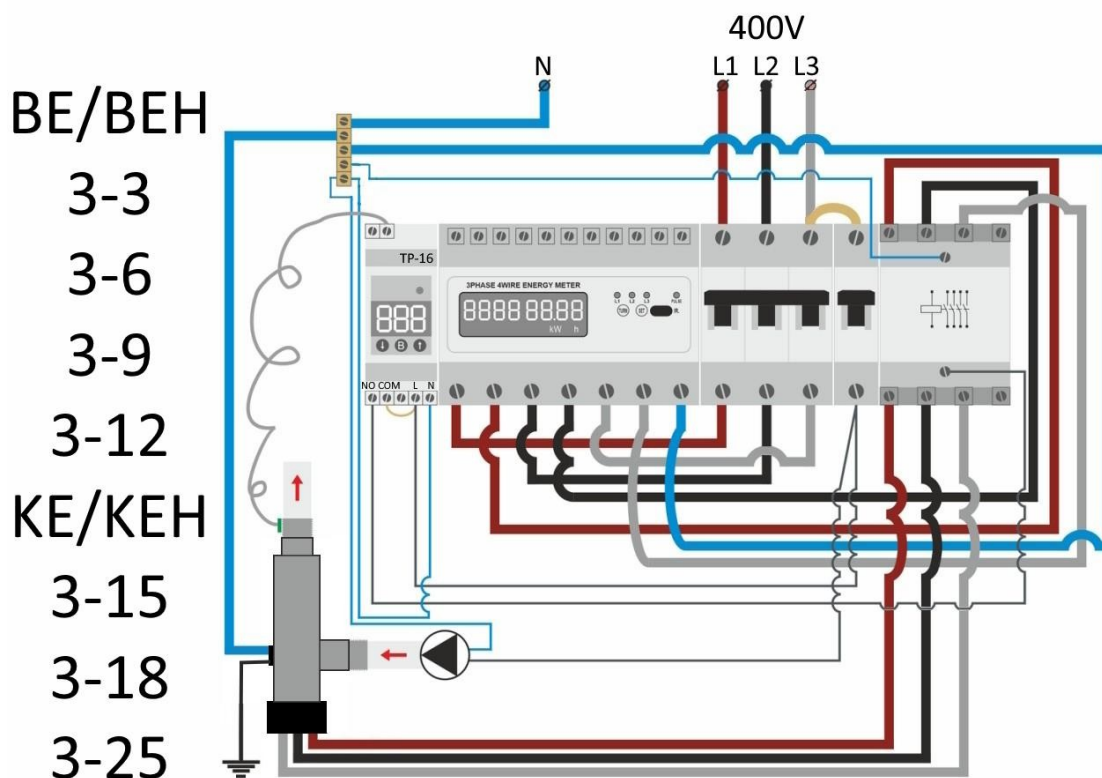

Below is a diagram of the automation with the possibility of connecting a room thermostat or other control device.

Fig. 2

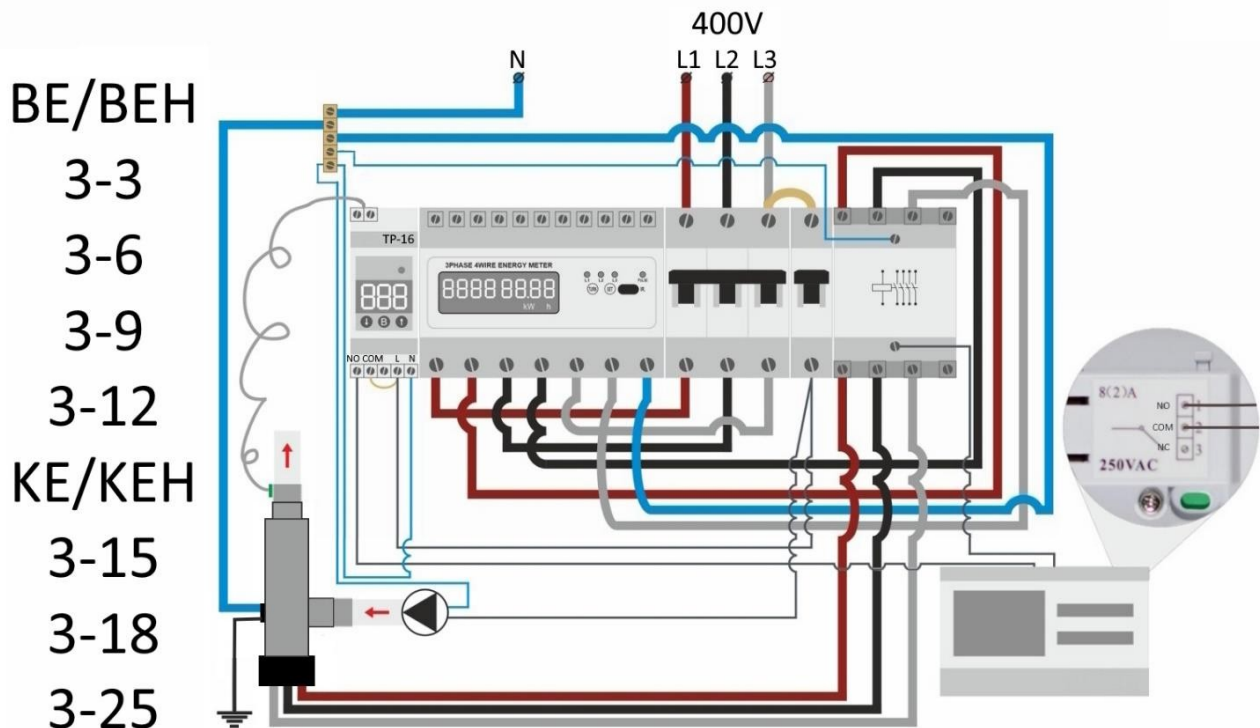

7.2 Automation Lux - KROS is the controller-controller of the KROS heating system. The automation greatly simplifies the commissioning and operation of the system with an electrode water heater,

Fig. 3

has extensive functionality and the highest degree of protection against all known hazards associated with the operation of electrical heating systems:

- The power circuits are switched by semiconductor devices, which ensures silence (no contactor clicks), reliability (no contact wear), safety (no sticking or burning of contacts)
- Infinitely variable and stabilised output of the water heater - the user can infinitely adjustable (and stabilised) power at 5...100%, allowing you to select the



the most economical mode of operation (especially in weak power networks).

- Display of current parameter levels on a digital display
- Independent control of two boilers - electrode and gas water heater (second boiler)
- Programmable day timer with real-time clock switches on/off/switches the boilers according to the daily programme set by the user. For example, in order to use the night-time electricity tariff, the electric boiler is programmed to operate between 23:00 and 7:00, and at other times of the day a separate command will be issued to the gas boiler (the second boiler).
- Use of tap water with an electrical conductivity of up to 1000 $\mu\text{s}/\text{sm}$ as a heat carrier
- The system is fully operational and maintains its performance with mains voltage fluctuations of 150 to 265 volts.
- Control of two circulation systems - separate channel (temperature sensor and control group for three-way valve contacts) for arrangement of the hot water supply system (in summer - without heating system) or underfloor heating, with independent temperature settings for the systems
- Possibility of parallel connection of an unlimited number of external control devices (room thermostats, radio-controlled actuators, 'smart home' system, etc.).

Fig. 4

The wiring diagram of one fully functional system is shown in Figure 4, where:

- 1 - electrode water heater
- 2 - heating system pump
- 3 - temperature sensor

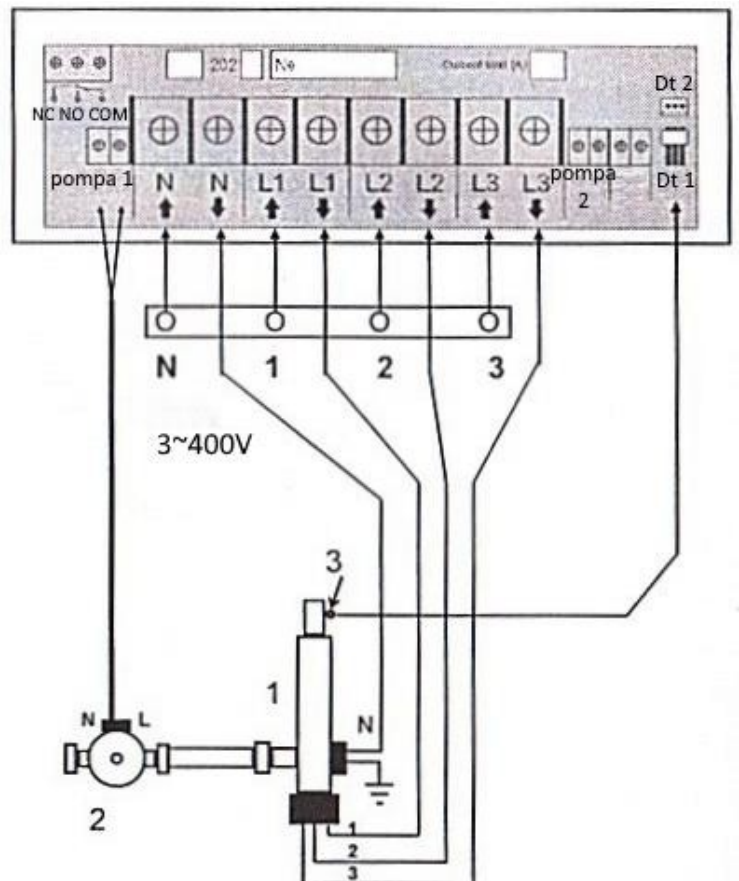

Connection diagram of two w fully functional systems are shown in Figure 5, where:

- 1 - electrode water heater
- 2 - heating system pump
- 3 - temperature sensor for the first heating system
- 4 - valve* or second DHW system pump
- 5- temperature sensor for second DHW system

GAZDA water heaters can cooperate with automation from other manufacturers, provided that its technical parameters comply with the requirements of this manual.

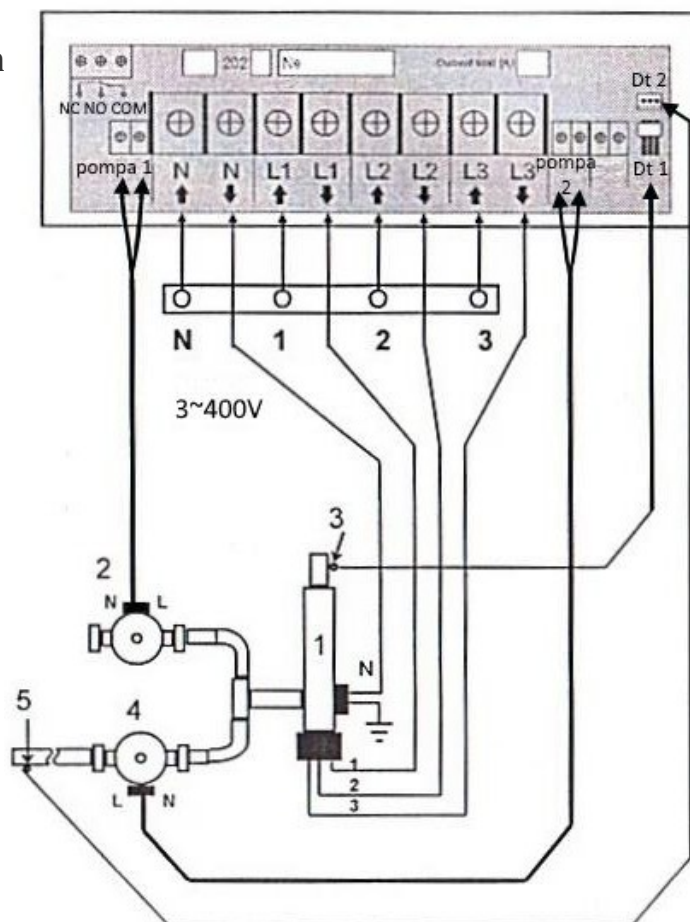

Installation of the electrical circuit must be carried out strictly adhering to the requirements of this manual and the wiring diagrams for the specific automation.

Copper cable shall be used for the installation, the cross-section and grade of which comply with point 7 of Table 1 and the requirements of the documents regulation of automation and accessories.

When connecting the wires to the terminal strip, strictly observe the connection points of "phase" (L) and "neutral conductor" (N) - according to the electrical equipment terminal plates.

8. Commissioning, operation and maintenance of the system

Irrespective of the condition of the piping and radiators of the heating system (new or used), the entire system must be thoroughly flushed before pumping in the prepared coolant; for this purpose, clean water must be pumped into the system, the circulation pump must be connected for 3...6 hours. If the system is old, flushing should be carried out with a corrosion inhibitor - according to the instructions for use. At the same time as flushing, leaks in the system should be removed.

Table 2

№	Water heater model and maximum power required	Outlet water heater current at 20°C	65°C outlet water heater current
1	BE/BEH 3-3 -2kW -3kW	1,2...1,4 1,7...1,9	2,9...3,2 4,3...4,7
2	BE/BEH 3-6 -4,5kW -6kW	2,6...2,9 3,5...3,8	6,5...6,9 8,7...9,3
3	BE/BEH 3-9 -7kW -9kW	4,2...4,5 5,5...5,8	10,1...10,8 13,3...13,9
4	BE/BEH 3-12 -10kW -12kW	6,1...6,4 7,4...7,7	14,5...15,4 17,4...18,5
5	BE/BEH 3-15 -12kW -15kW	7,4...7,7 9,1...9,5	17,3...18,4 22,0...22,9
6	KE/KEH 3-18 -15kW -18kW	8,0...9,0 9,5...10,5	21,5...22,5 26,0...27,0
7	KE/KEH 3-25 -22kW -25kW	11,0...13,0 13,0...15,0	31,5...33,0 36,0...37,5
8	KE/KEH 3-50 -40kW -50kW	21,0...24,0 26,0...30,0	59,0...61,0 75,0...77,0

Then drain the flushing water completely and clean the strainer. Pour the prepared coolant into the system.

Before starting the system for the first time, ensure that the electrical and hydraulic parts of the system are complete, check the correctness and reliability of the wiring and equipment.

Start the system - switch on the power and select the desired operating parameters. Monitor the coolant temperature at the outlet of the water heater and the current of the water heater and compare them with the values in Table 2.

When starting a heating system in a large cooled room when the water temperature in the system rises for a long time, it is advisable to switch off 30-50% of the heaters while the water heater is running. This will reduce the time heating water in a 'shortened' heating system and will reduce the total time for adjusting the electrical conductivity of the coolant, if necessary.

If, after the maximum water temperature has been reached, the current does not correspond to the value given in Table 2, i.e. it is necessary to adjust the electrical conductivity of the coolant, open all radiators and wait until the water is completely mixed throughout the system before adding the next portion of baking soda or distilled water.

If, after "shortening" the system to the set mode, the current corresponds to the nameplate current, turn on all heaters and wait for the mode steady state for the entire heating system and then measure the load current again. If, at 65°C, the current consumption of the water heater is within the limits set out in Table 2, the system can be considered complete.

After 7...10 days of system operation (especially important for systems with old pipes and radiators), measure the current and readjust the electrical conductivity of the heat carrier if necessary.

Further operation of the water heater does not require any user intervention, except for adjusting the settings of the automation parameters in order to

to provide the most comfortable and economical space heating.

It should be understood that the efficiency of the heating system is primarily about good thermal insulation of the heated room and weather-dependent heating control (room thermostat).

If the system is working properly, the water heater does not require any maintenance, with the exception of checking the tightness of the pipe fixing nuts once a year, before the start of the heating season.

At the end of each heating season, the mesh filter in the heating system should be cleaned.

When operating the system with the expansion tank open, add water to the normal level:

- distilled water (rain water, snow water) - when the level is reduced by evaporation;

- "basic" (see section 6) coolant if the drop in level is due to a leak

9. Possible faults and how to rectify them

Situation	Probable cause	Remedy
<p>1. When power is supplied to the water heater, the following is triggered circuit breaker</p>	<p>The cut-off current of the appliance is lower than the actual current of the water heater.</p> <p>Short circuit in the wiring, incorrect water heater connection</p> <p>The electrical conductivity of the coolant far exceeds the requirements of this Guide</p>	<p>Replace the machine if its cut-off current is lower than the maximum current rating of the water heater.</p> <p>Check the wiring for the presence of a short circuit and the compatibility of the connection of the wires "phase" and "zero"</p> <p>Replace coolant or adjust conductivity electricity in accordance with paragraph 6</p>
<p>2. The water heater current corresponds to the initial rated value, but the system does not heat up to the maximum temperature</p>	<p>The actual volume of the coolant is greater than the requirements set out in point 8 of Table 1</p> <p>The heat output of the radiators is higher than that of the water heater</p>	<p>Apply the system method "shortened" (see section 8) or install radiators with a smaller volume</p> <p>Switch off some of the radiators or install a more powerful water heater</p>
<p>3. Water heater gradually loses power, regulation and coolant replacement have no effect</p>	<p>Dielectric splatter has formed on the surface of the electrode and housing (inside) Increased electrode wear:</p> <ul style="list-style-type: none"> • due to the presence of aggressive contaminants in the coolant • poor power quality (presence of a constant component in the alternating current, the electrode is destroyed by electrolysis) 	<p>Remove the electrode, clean it and the inner surface of the water heater body</p> <p>Replace the electrode and coolant</p> <p>Connect the system power supply to another phase (in the case of single-phase entry, the decision is agreed with the electricity supplier)</p>
<p>4. The heater gradually increases in power</p>	<p>Salt deposits are flushed out of the old system</p>	<p>Flush the system with inhibitor, top up with new coolant</p>